

Joints and ferrules

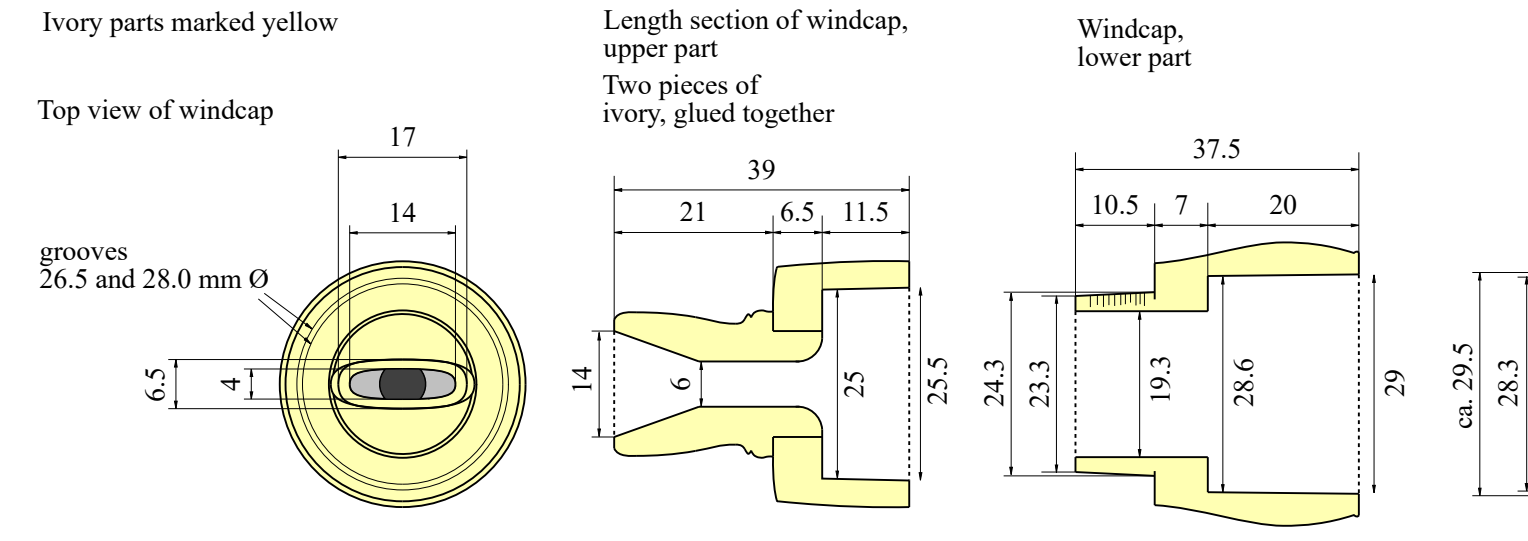

Turning details 2:1

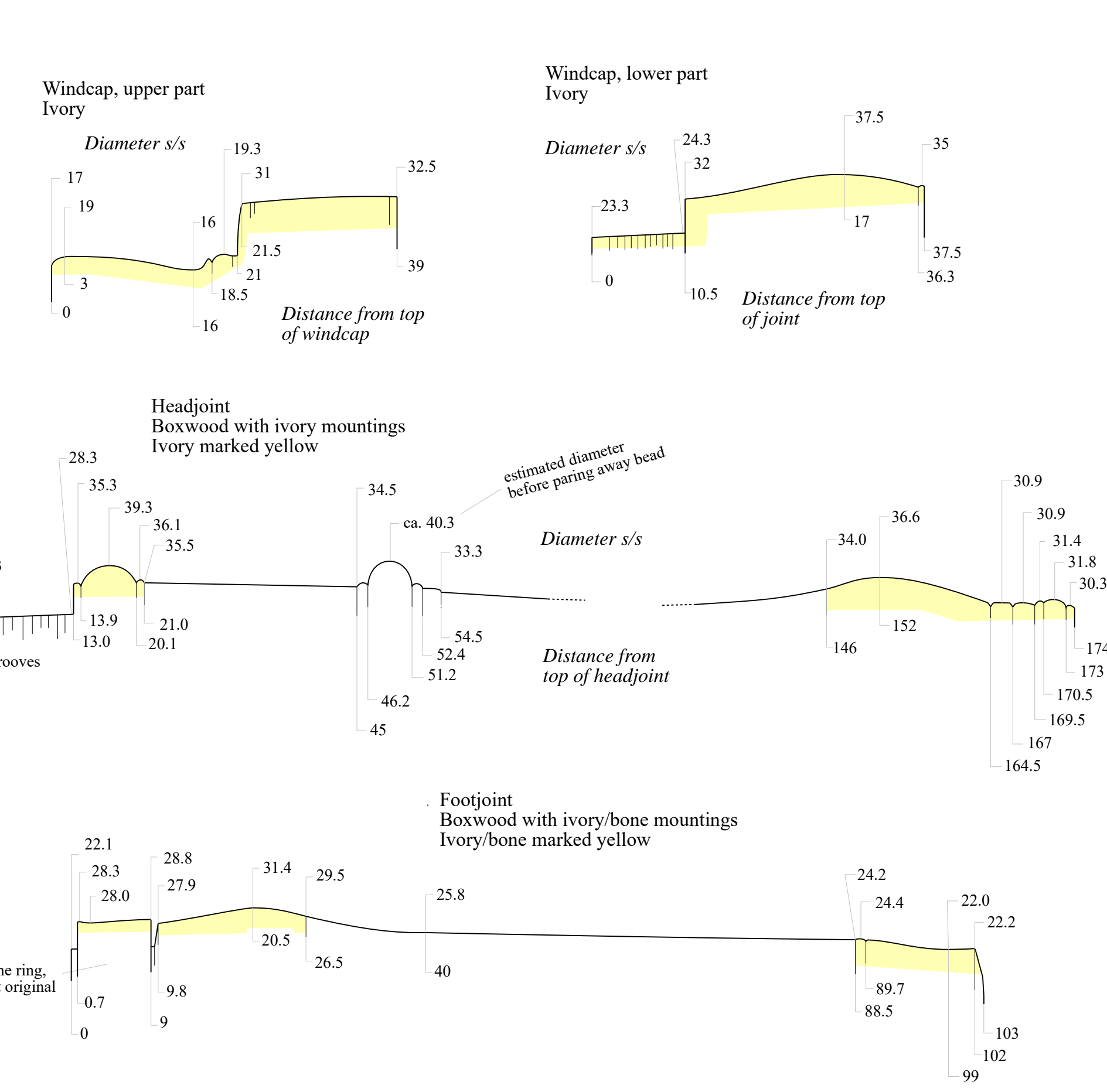

Bore dimensions

Length from top	Diameter side/side	Diameter front/back	
60	19.1		
70	19.1	19.1	
80	19.1	19.1	
90	19.1	19.0	
100	19.1	19.0	
110	19.1	19.0	head-joint
120	19.1	19.1	
130	19.1	19.0	
140	19.1	19.0	
150	19.2	19.0	
160	18.4	18.2	
170	18.4	18.3	
180	18.3	18.3	
190	18.0		
190	17.7	17.7	
210	17.6		
220	17.4	17.4	
230	17.3	17.4	
240	17.1		
250	17.1	17.2	
260	17.0	17.0	
270	16.9		
280	16.6	16.7	middle joint
290	16.5	16.5	
300	16.4	16.4	
310	16.2		
320	16.1	16.2	
330	15.8	16.0	
340	15.5	15.6	
345	15.2	15.2	
350	14.8	14.9	
355	14.6	14.7	
360	14.4	14.4	
370	14.0	13.9	
375	13.8	13.7	
380	13.5	13.2	
385	13.1	12.9	
390	12.9	12.5	
400	12.5	12.9	
410	12.5	12.4	
420	12.3	12.2	
430	11.9	11.8	
440	11.6	11.4	foot-joint
450	11.5	11.4	
460	11.5	11.3	
470	11.6	11.2	
475	11.6	11.3	

Finger holes

Finger hole No.	Distance from top of headjoint to center of hole	Ø side/side	Remarks
0	192.5	6.0	= thumb hole
1	209	5.8	
2	237.5	6.2	
3	270	5.7	
4	308	5.6	
5	335.5	5.7	
6	363.5	4.8	
7	392	5.4	20° downwards

Inner bore

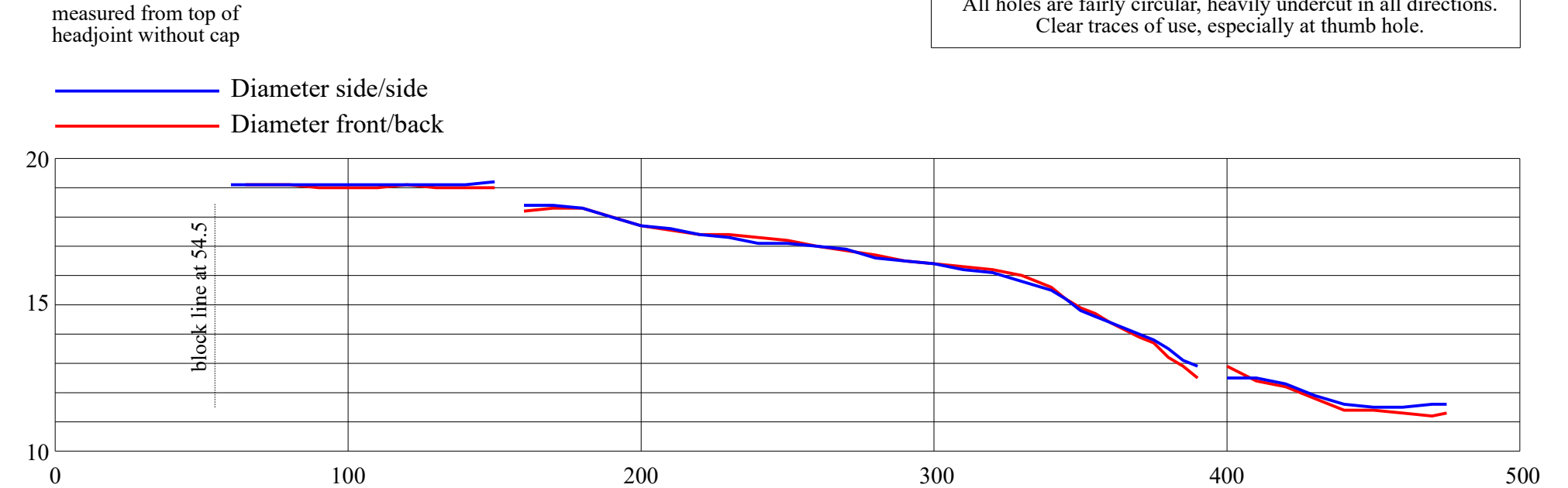

Recorder in f' with flageolet-like mouthpiece by Carlo Palanca, Turin

Musikmuseet, Musikhistorisk Museum & Carl Claudius' Samling, Copenhagen, Denmark
Inv. No. E 86

Boxwood recorder with ivory windcap and mountings. The flageolet-like windcap seems to be original. The upper end of the windway is badly damaged by pressure of the cap caused by moisture from the player's breath, and there is a heavy crack along the right side of the windway. The windway is so narrow due to the compression that inspection is very difficult and playing impossible. The front part of the beak (inside the windcap) has been removed. The pitch is estimated to a=426-430 Hz.

Measured and drawn May/June 2013 by Ture Bergstrom, Musikmuseet, Copenhagen

© Musikmuseet, Musikhistorisk Museum & Carl Claudius' Samling, Copenhagen, Denmark 2013.
Private copying of this drawing is allowed, but it may not be published in any form without written permission from the museum.
Resale in any form is not allowed.

